

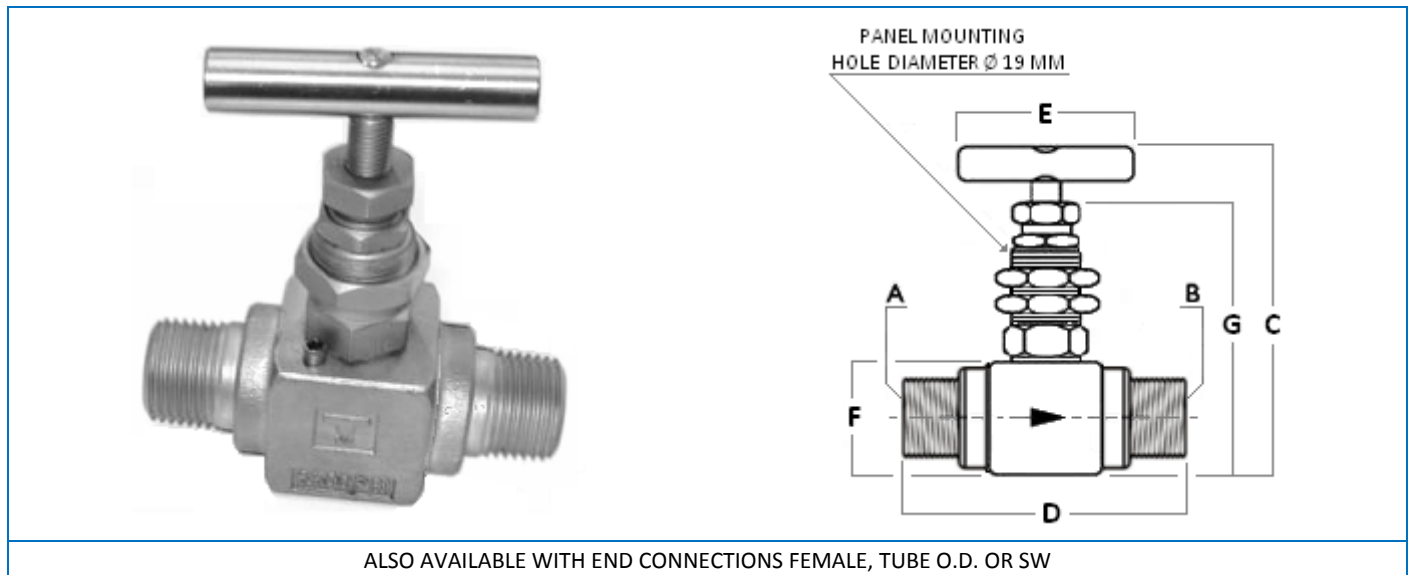

Needle Valves 400MP Series

Male Thread to Male Thread – 1 Way – for panel



PART NUMBER	INOX 316	404 MP 316	404 MBP 316	406 MP 316	406 MBP 316	408 MP 316	408 MBP 316	
	CARBONO	404 MP S	404 MBP S	406 MP S	406 MBP S	408 MP S	408 MBP S	
END CONNECTIONS	INLET (A)	1/4" NPT MALE	1/4" BSP MALE	3/8" NPT MALE	3/8" BSP MALE	1/2" NPT MALE	1/2" BSP MALE	
	OUTLET (B)							
DIMENSIONS*	C	OPEN: 91,00 CLOSED: 88,50						
	D	65,50				67,00		
	E	55,00						
	F	31,75						
	G	67,50						

* Dimensions are for reference only and are subject to change.

OPTIONALS & KEY FEATURES	
VARIOUS STANDARD END-CONNECTIONS FROM 1/8" TO 1"	17-4 PH STAINLESS STEEL NON-ROTATING STEM TIP
CHOICE OF 316 STAINLESS STEEL (CF8M) OR CARBON (WCB)	NPT THREADS OR BSP THREADS – MM OR INCHES
TEFLON® PACKING OR GRAFOIL® PACKING	MAXIMUM OPERATING PRESSURE: 6.500 PSI
STRAIGHT AND ANGLE PATTERNS	JOINT IS LOCATED ABOVE THE PACKING, PROTECTED FROM SYSTEM

Technical Standards



		STANDARDS – RAW MATERIAL		400 MP
		DESCRIPTION		
	Nº	SS 316 (316)	CARBON (S)	
	1	ROUND BAR (316) ASTM A 276	ROUND BAR (S) SAE 1020 / 1045	
	2	SCREW ALLEN (304) DIN 915	SCREW ALLEN (S) DIN 915	
	3	HEX BAR (316) ASTM A 276	HEX BAR (S) SAE 1020 / 1045	
	4	HEX BAR (316) ASTM A 276	HEX BAR (S) SAE 1020 / 1045	
	5	WASHER (316) ASTM A 167		
	6*	PTFE 850A (TEFLON®) ASTM D 4894 GRAFKOTE (GRAFOIL®) ASTM F 1315		
	7	HEX BAR (316) ASTM A 276	HEX BAR (S) SAE 1020 / 1045	
	8	PTFE 850A (TEFLON®) ASTM D 4894		
	9	ROUND BAR (316) ASTM A 276		
	10	ROUND BAR ARMCO 17-4 PH ASTM A 564 TP 630		
	11*	HEX BAR(316) ASTM A 276		
	12	SPRING PIN (304) DIN 1481	SPRING PIN (S) DIN 1481	
13*	BODY VALVE (CASTING) (CF8M) ASTM A 351	BODY VALVE (CASTING) (WCB) ASTM A 216		
	SQUARE BAR (316) ASTM A 276	SQUARE BAR (S) SAE 1020 / 1045		

* OPTIONAL

VALVES BODIES TREATMENT			
COMPONENT		TREATMENT	STANDARD
ALL (EXTERNALS)	SS 316 (CF8M)	GLASS BEAD BLASTING	TRIUNION'S STANDARD
	CARBON (WCB)	CHROMATE NON-HEXAVALENT (COLORLESS)	

OXYGEN CLEANING			
COMPONENT		TREATMENT	STANDARD
ALL	SS 316 (CF8M)	ROCOL® FLUOR CLEAN OR SIMILAR	ASTM G 93
	CARBON (WCB)		

PRESSURE TESTING			
PRODUCTS	TESTING PROCEDURES		STANDARD
	SHELL	SEAT	
VALVES	9.750 PSI – 15 SEC ROOM TEMPERATURE	7.150 PSI – 15 SEC ROOM TEMPERATURE	MSS SP 82 BS EN 12266



Technical Information

Valves for Panel – 400P Series – 1 way

TECHNICAL DATA		SS 316	CARBON	
S T A N D A R D S	CONSTRUCTION		BODY: ASME B 16.34	
			END CONNECTION: ASME B 16.11	
	RAW MATERIAL (ASME B 31.1)	BODY (OPTIONAL)	SS 316 - CASTING (CF8M) – ASTM A 351	CARBON - CASTING (WCB) – ASTM A 216
			BAR ASTM A 276 TP 316	BAR SAE 1020 / 1045
		NEEDLE	ARMCO 17-4 PH – ASTM A 564	
		PACKING (OPTIONAL)	GASKETS: CHOICE OF TEFLON® (POLYACETAL) OU GRAFOIL®	
INTERNAL	ALL SS 316 - ASTM A 276			
PANEL MOUNTING HOLE DIAMETER		Ø 19 MM		
CONSTRUCTIVE FORM OF THE STEM		SINGLE PIECE WITHOUT WELDING		
HANDLE		T-BAR SS 304 / SS 316 Ø – ASTM A 276	T-BAR CARBON Ø – SAE 1020 / 1045	
ACTUATOR		DIRECT BY HANDLE		
TYPE		NEEDLE TYPE GLOBE VALVE		
SEAT		METAL SEAL BETWEEN BODY AND BONNET REPLACEABLE		
NEEDLE TIP		NON ROTATING TIP – SELF CENTERING AND ANTI-GALLING		
END CONNECTIONS FOR TUBE O.D.		TWO FERRULES SYSTEM		
WORKING PRESSURE		6.500 PSI (MAXIMUM)		
ORIFICE SIZE / CV		Ø 4 MM / CV 0.36 (MAXIMUM)		
BURST PRESSURE		DESIGNED WITH 4 : 1		
TEMPERATURE RANGE (OPTIONAL PACKING)		TEFLON® = (-) 50° C A + 200° C GRAFOIL® = (-) 50° C A + 600° C		
TESTING PROCEDURES		STANDARDS BS EN 12266-1:2003 / BS EN 1266-2:2003 / MSS-SP-82 100% FACTORY TESTED 9.750 PSI – 15 SEC – ROOM TEMPERATURE		
KEY FEATURES				
HIGH PRESSURE CAPABILITY, 316 STAINLESS STEEL OR CARBON VALVE MAXIMUM WORKING PRESSURE IS 6.500 PSI (448 BAR) AT ROOM TEMPERATURE.				
PACKING STEM SEATS BELOW STEM THREADS, TO PROTECT STEM THREADS FROM ABRASIVE FLUIDS.				
REPAIR SEAT KIT ON AVAILABLE TO EXCHANGE				
100% FACTORY TESTED, ALL VALVES HAVE NEEDLE NON-ROTATING HARDNED (17-4 PH) TIPS AS STANDARD.				
DIFERENT TYPE OF THE END CONNECTIONS: DOUBLE FERRULE TYPE, SW, MALE, FEMALE, NPT OR BSP THREADS, INCHES AND MM.				